

Product Features

- 900mm Stainless steel gas cooktop
- 5 gas burners - 1 x triple ring wok (13.6 Mj/h), 1 rapid (11.7 Mj/h, 2 x semi rapid (7.1 Mj/h each) and 1 x auxiliary (3.9 Mj/h)
- Wok adaptor supplied
- Front control
- Electronic knob ignition
- Cast iron trivets
- 10 amp connection
- LPG jets and labels are supplied

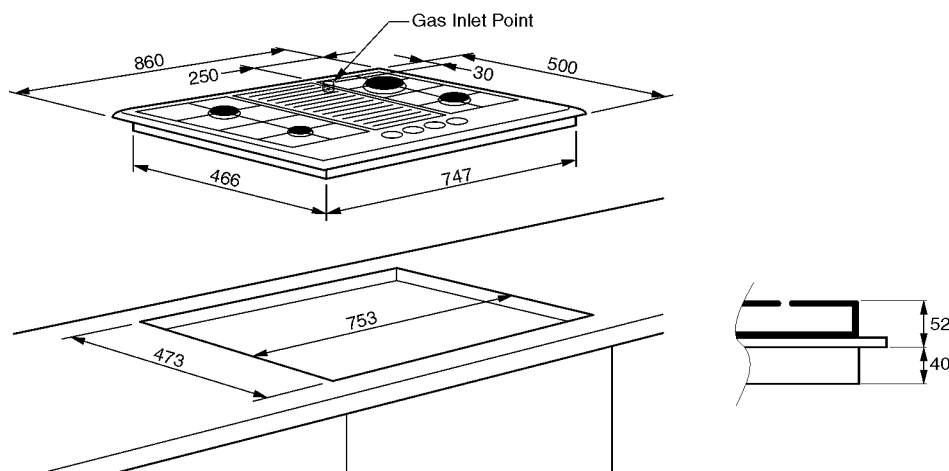

Dimensions



WARNING: technical specifications and product sizes can be varied by the manufacturer without notice. Cut-outs for appliances should only be by physical product measurements. The above information is indicative only.

Installation must only be carried out by a licensed installer in line with the relevant state or national regulatory requirements.

PLEASE NOTE incorrect installation will void all warranties